

THIS IS YOUR MACHINE LEARNING SYSTEM?

YUP! YOU POUR THE DATA INTO THIS BIG PILE OF LINEAR ALGEBRA, THEN COLLECT THE ANSWERS ON THE OTHER SIDE.

WHAT IF THE ANSWERS ARE WRONG?

JUST STIR THE PILE UNTIL THEY START LOOKING RIGHT.



# FUNDAMENTAL COMPONENTS OF DEEP LEARNING

A CATEGORY-THEORETIC APPROACH

BRUNO GAVRANOVIĆ

ONLINE MACHINE LEARNING SEMINAR

SEP. 20. 2023

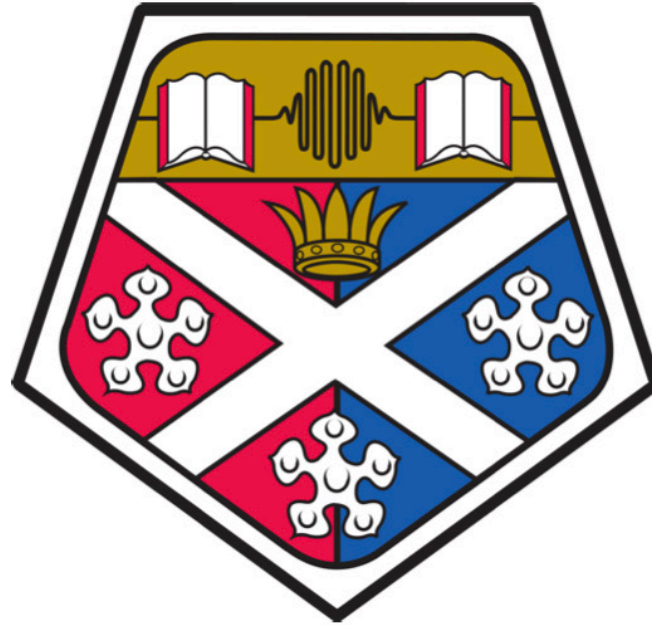

# Fundamental Components

## of Deep Learning

A category-theoretic approach

PhD Thesis

DEEP LEARNING ?

# A NEW FIELD

- DEEP LEARNING IS A YOUNG FIELD
- SCIENTIFIC FIELDS OFTEN START IN AN AD-HOC MANNER
- LATER THEY ARE UNDERSTOOD DIFFERENTLY THAN BY THEIR EARLY PRACTITIONERS
  - TAXONOMY
  - PROGRAMMING
  - CHEMISTRY

# CHEMISTRY STARTED AS ALCHEMY

- ALCHEMY WORKED
- RESPONSIBLE FOR MANY PRACTICAL ADVANCEMENTS
- DOCUMENTED MANY NEW AND UNEXPLAINED PHENOMENA
  
- NO UNDERSTANDING OF FUNDAMENTAL PRINCIPLES
- AD-HOC, LARGELY BASED ON HEURISTICS
  
- GRANDIOSE MOTIVATIONS

# DEEP LEARNING ~ ALCHEMY ?

- DEEP LEARNING WORKS
- RESPONSIBLE FOR MANY PRACTICAL ADVANCEMENTS
- DOCUMENTING NEW AND UNEXPLAINED PHENOMENA:
  - DOUBLE DESCENT, GROKING
  - LOTTERY TICKET HYPOTHESIS
  - SCALING LAWS
  - IN-CONTEXT LEARNING

...

- NO UNDERSTANDING OF FUNDAMENTAL PRINCIPLES
- AD-HOC, LARGELY BASED ON HEURISTICS
  - INDIVIDUAL COMPONENTS ARE WELL-UNDERSTOOD, THEIR COMPOSITIONS AND COMBINATIONS ARE NOT
- GRANDIOSE MOTIVATIONS



# ALCHEMY TURNED INTO CHEMISTRY

- WE CAN ACTUALLY CURE MANY DISEASES ALCHEMISTS WERE TRYING TO CURE
- BUT OUR UNDERSTANDING OF WHAT WE ARE DOING IS BASED ON COMPLETELY DIFFERENT PRINCIPLES

# DEEP LEARNING TURNED INTO ?

- THE DEEP LEARNING COMMUNITY IS AWARE THIS
- VARIOUS WORKSHOPS ON COMPOSITIONALITY
- CALLS FOR A DEEP LEARNING „LANGLANDS“ AND „ERLANGEN“ PROGRAMME
- NO WIDESPREAD CONSENSUS ON HOW TO REACH THAT GOAL

# ENTER CATEGORY THEORY

- EXCITING FIELD THAT'S BEEN GROWING IN RELATIVE OBSCURITY

- BASED UPON THE IDEA OF

COMPOSITIONALITY

- "21<sup>ST</sup> CENTURY MATHEMATICS"

- A GOOD WAY TO ORGANIZE THOUGHTS

"THE MORE CLEAN AND CONSISTENT YOUR  
ABSTRACTIONS ARE, THE MORE IT WILL SEEM  
LIKE YOU WERE ABIDING BY THE LAWS OF  
CATEGORY THEORY."

Category theory takes a bird's eye view of mathematics. From high in the sky, details become invisible, but we can spot patterns that were impossible to detect from ground level.



# CT $\cap$ ML

CT  $\cap$  ML: Cumulative number of papers through time

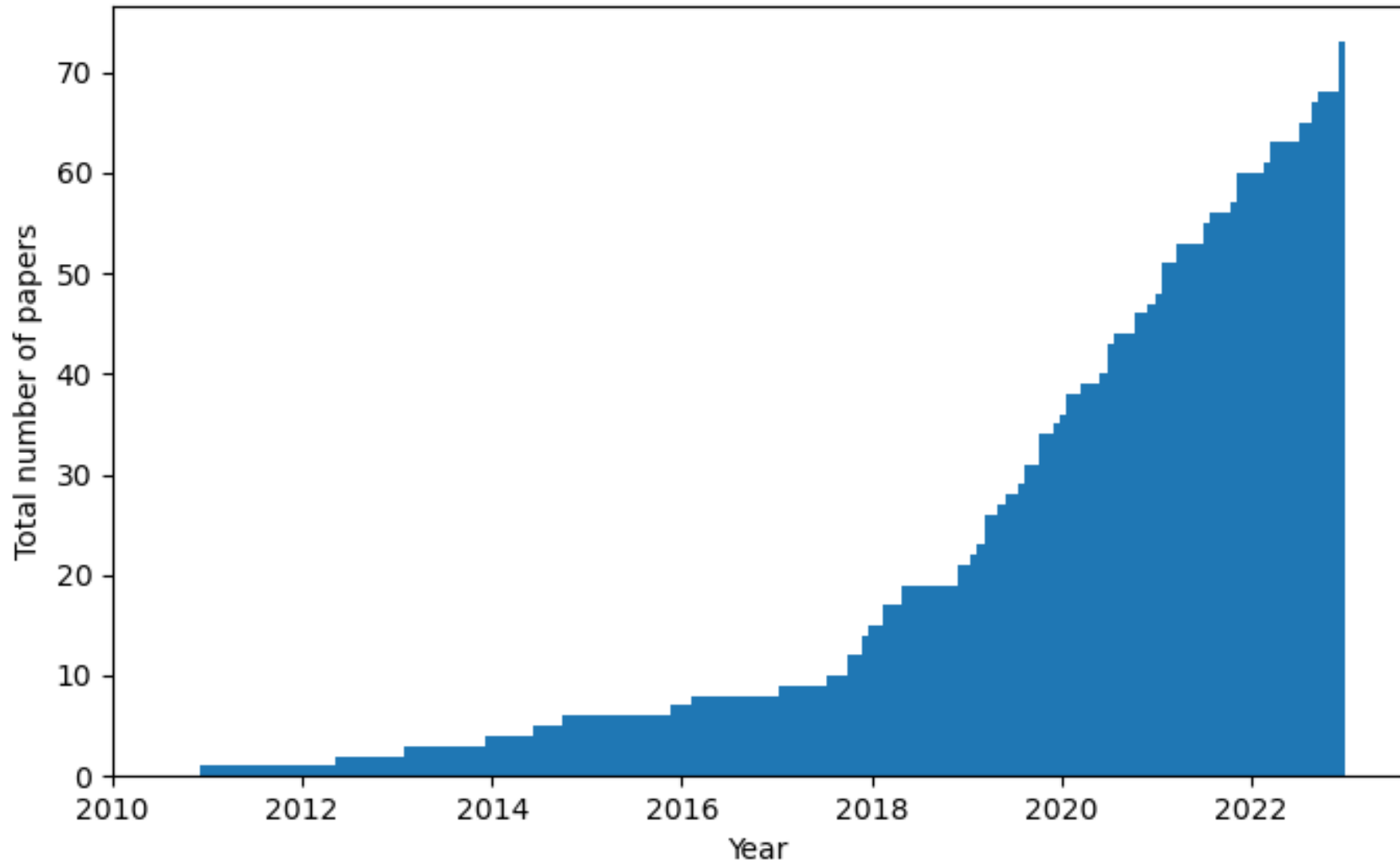

“While diagrams of networks have been independently introduced in many disciplines, we do not expect formalizing these diagrams to immediately help the practitioners of these disciplines. At first the flow of information will mainly go in the other direction: by translating ideas from these disciplines into the language of modern mathematics, we can provide mathematicians with food for thought and interesting new problems to solve. We hope that in the long run mathematicians can return the favor by bringing new insights to the table.”

BAEZ, FONG

• TYPE 1 VS. TYPE 2 FIELD OF ACT

GOAL:

PROVIDE A CATEGORICAL FRAMEWORK

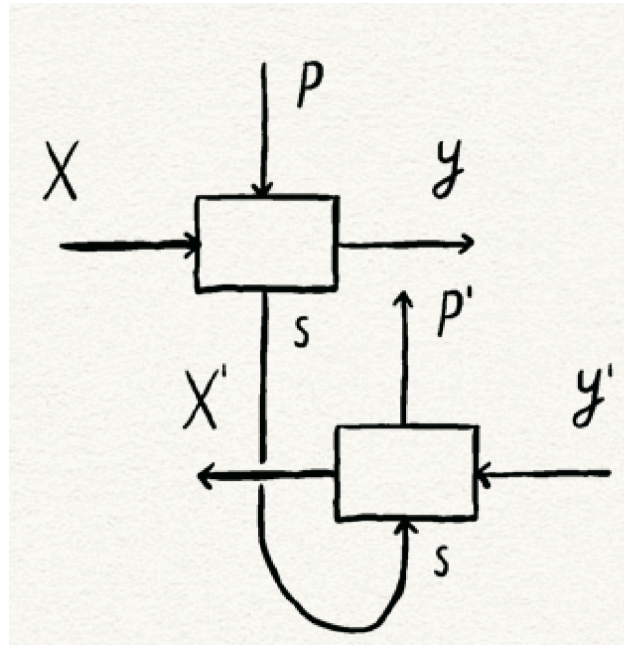

FOR DEEP LEARNING



GOAL:

PROVIDE A CATEGORICAL FRAMEWORK

—

FOR DEEP LEARNING

# SUPERVISED LEARNING WITH NEURAL NETWORKS IN ONE SLIDE:

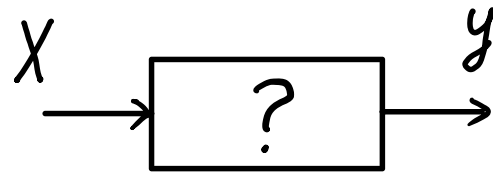

TASK: FIND A FUNCTION  $X \rightarrow y$  THAT BEST FITS

A DATASET: List  $X \times y$



INPUT

$X$

NEURAL NETWORK  
WEIGHTS

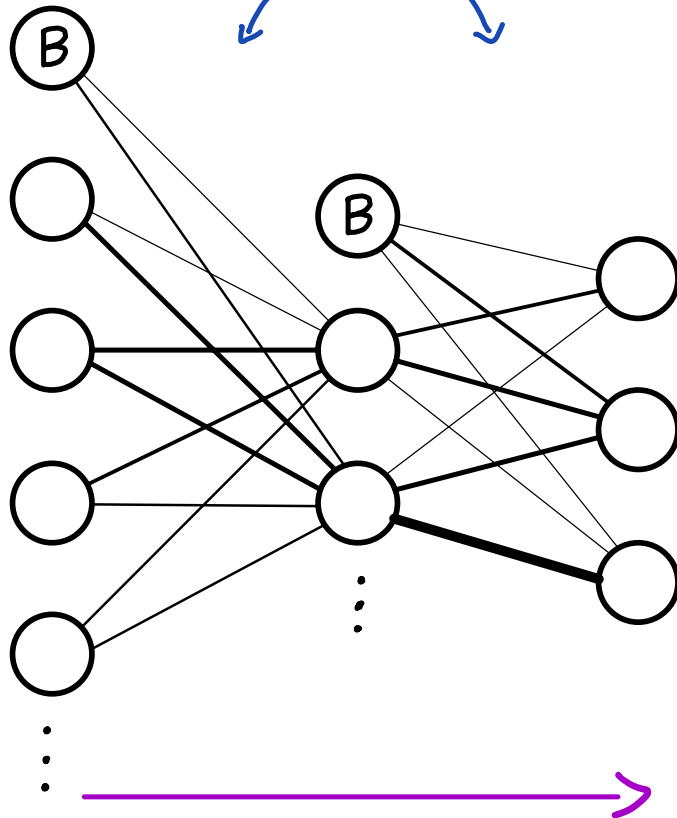

1 CAT  
+  
0 DOG  
+  
0 HORSE

LABEL

$y$

PREDICTION

$\hat{y}$

0.4 CAT  
+  
0.5 DOG  
+  
0.1 HORSE



$R$

GOAL: DISENTANGLE COMPONENTS OF THE  
BLACK BOX OF NEURAL NETWORKS:

•PARAMETRICITY

•BIDIRECTIONALITY

AND IN DOING SO ESTABLISH FORMAL CONNECTIONS TO

•GAME THEORY

•RL

•DIFFERENTIAL GEOMETRY

•DYNAMICAL SYSTEMS...

MIGHT NOT TELL YOU ANYTHING „NEW“!

WILL HOPEFULLY GIVE YOU A NEW PERSPECTIVE

# WHAT IS A CATEGORY?

- NETWORK OF RELATIONSHIPS

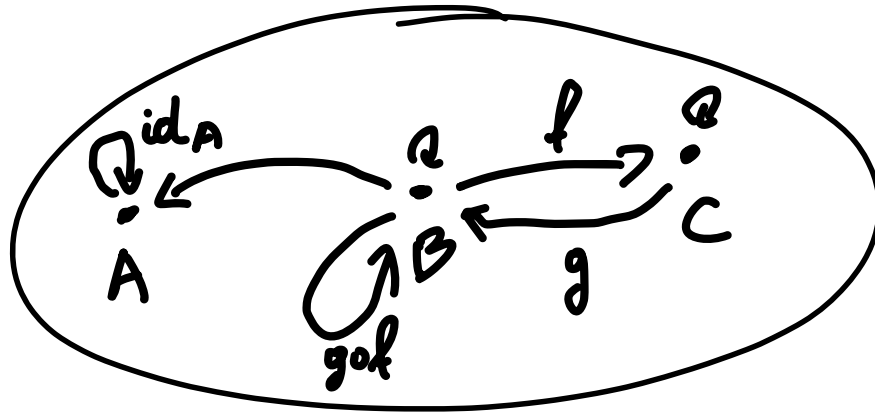

- ABSTRACT, BUT PRECISELY SPECIFIED CONCEPT

# Category: definition

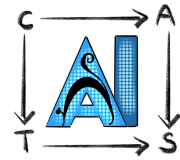

A category: a *universe* of **objects**, and **morphisms** between them, s.t.:

(The word “*universe*” is used here deliberately instead of “*set*”, to avoid *paradoxes*)

- For  $f: A \rightarrow B$  and  $g: B \rightarrow C$ , there is a **composition**,  $g \circ f: A \rightarrow C$
- For each object  $A$ , there is a unique **identity** morphism  $\text{id}_A: A \rightarrow A$
- For any morphism  $f: A \rightarrow B$ , it holds that  $\text{id}_B \circ f = f \circ \text{id}_A = f$
- For any composable  $f, g, h$ , we have  $h \circ (g \circ f) = (h \circ g) \circ f$

The collection of morphisms between  $A$  and  $B$  is often denoted  $\text{Hom}(A, B)$

(the “**hom-set**” from  $A$  to  $B$ )

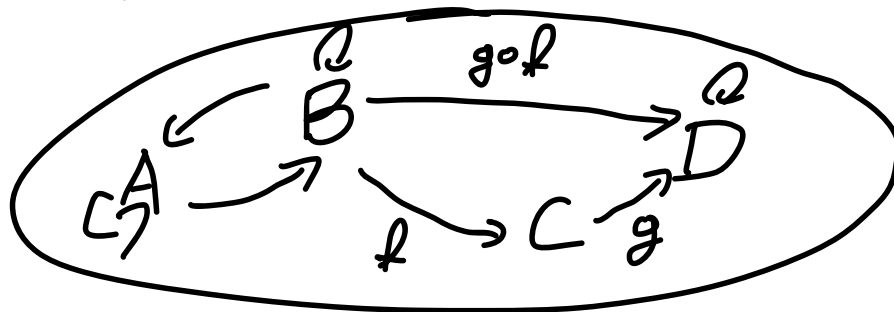

# Category: examples

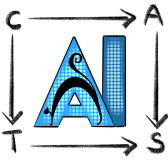

- Set - sets and functions
- Rel - sets and relations
- Vect - vector spaces and linear transformations
- $\mathbb{R}$  - numbers and order relations
- Grp - single objects, group elements are morphisms

$\mathbb{R}$

$$2 \leq 3$$



- WE OFTEN USE CATEGORIES TO BUILD OTHER CATEGORIES
- WE DESCRIBE ABSTRACT PROPERTIES OF CATEGORIES
- CAN WE DESCRIBE AFOREMENTIONED PROPERTIES OF NNs?
- GOAL IS TO CAPTURE ALL RELEVANT EXAMPLES!

# BASIC NN LAYER

$$f: \mathbb{R}^k \rightarrow \mathbb{R}^{k'}$$
$$f(x) = \sigma(xW)$$

$$1 \left[ \begin{array}{c} k \\ X \end{array} \right] \left[ \begin{array}{c} k' \\ W \end{array} \right]$$

$k$  - NUMBER OF INCOMING FEATURES

$k'$  - NUMBER OF OUTGOING FEATURES

EACH LAYER HAS ITS OWN WEIGHT MATRIX

# PARA CONSTRUCTION

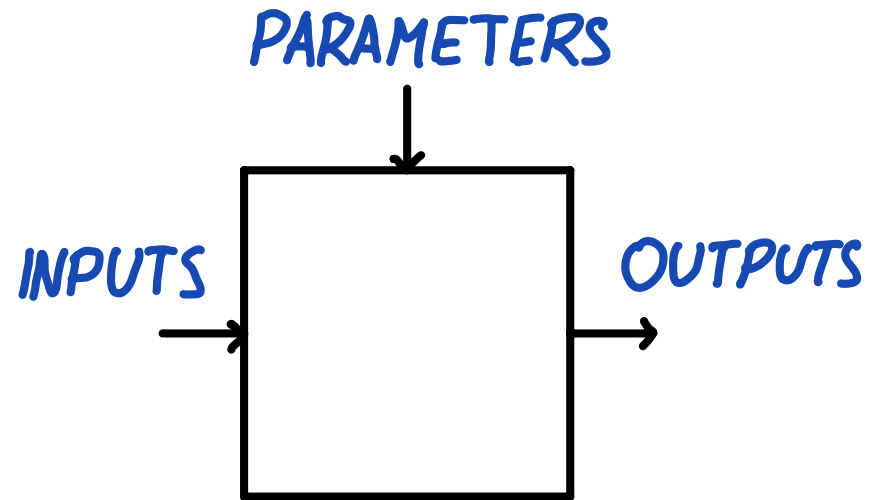
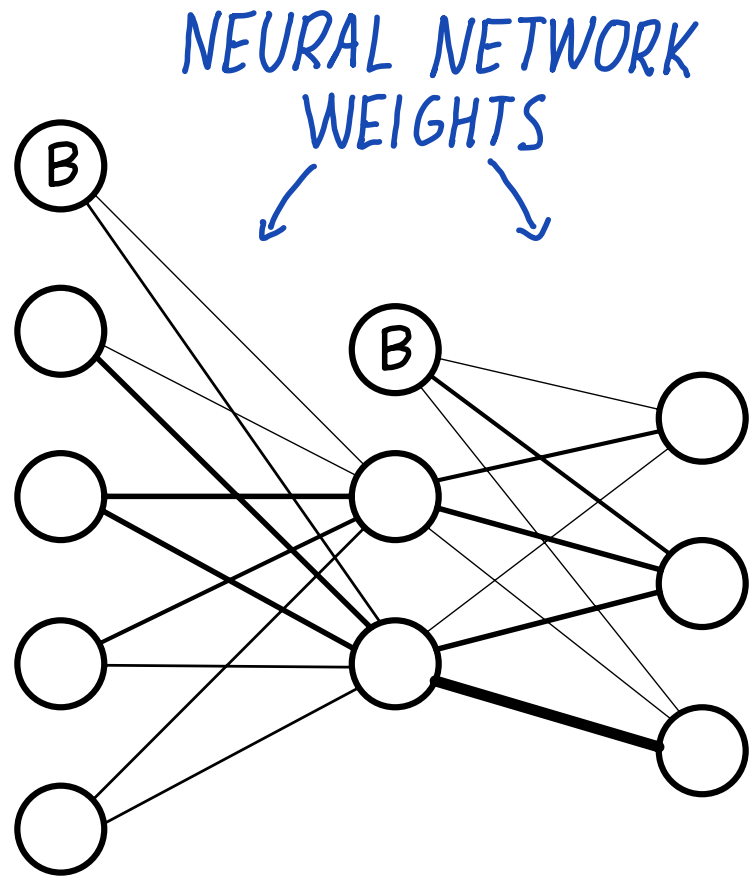

**FIX A MONOIDAL CATEGORY  $(\mathcal{C}, \otimes, I)$ .**

**Para( $\mathcal{C}$ ) IS A BICATEGORY WHERE**

$$\text{Para}(\mathcal{C})(A, B) := \sum_{P: \mathcal{C}} \mathcal{C}(P \otimes A, B)$$

$$A \xrightarrow{P, f: P \times A \rightarrow B} B$$

$$A \xrightarrow{(P, f)} B \xrightarrow{(R, h)} C$$

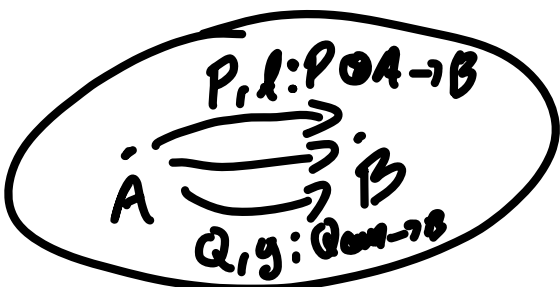

Para( $\mathcal{C}$ )

**PARAMETERS**

**INPUTS**

**OUTPUTS**

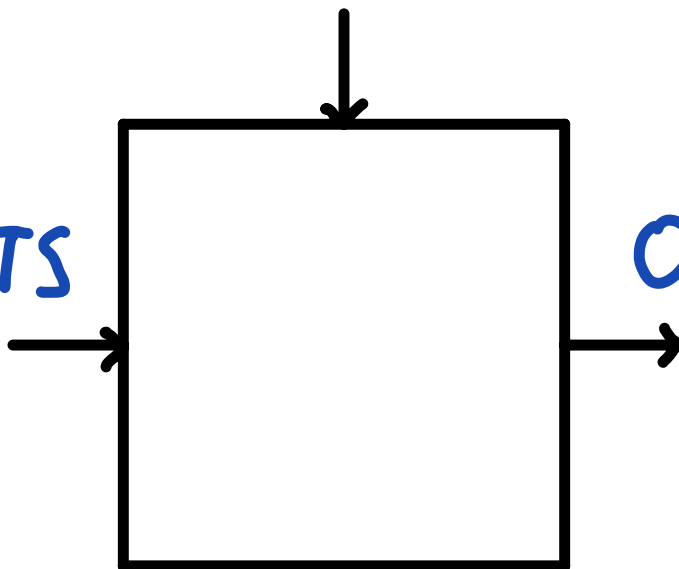

# COMPOSITION TENSORS THE PARAMETERS

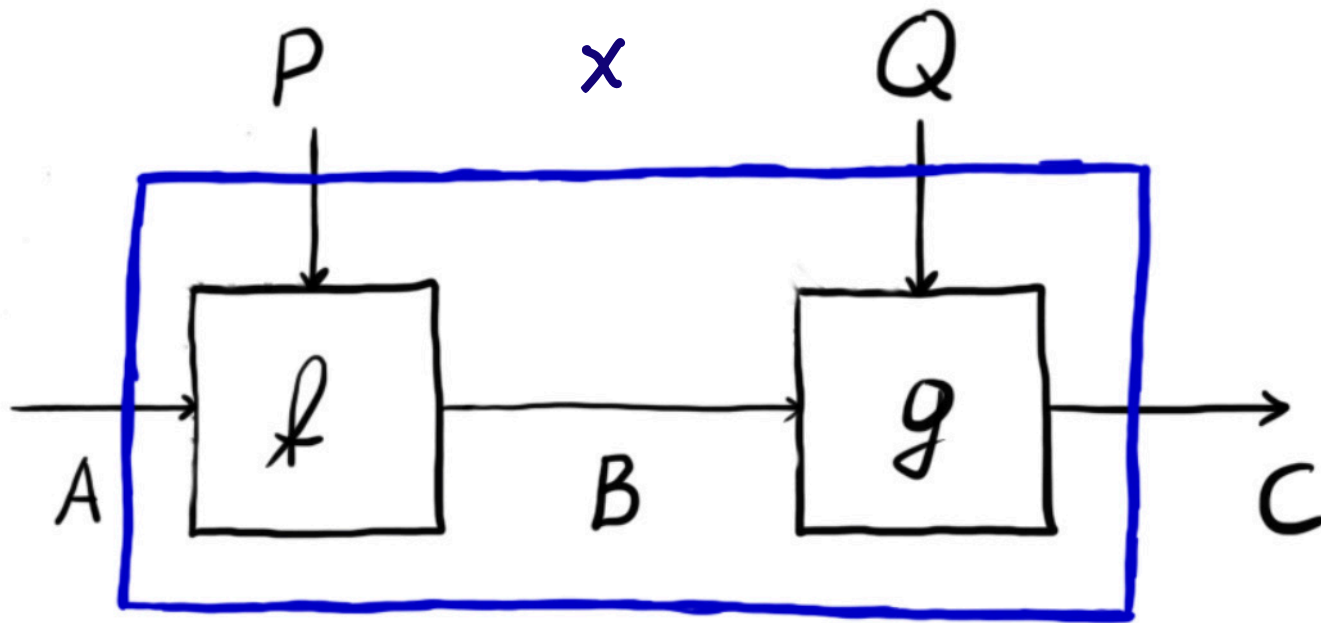

# GRAPHICAL LANGUAGE

TEXTUAL  
NOTATION

$$f: P \otimes A \longrightarrow B$$

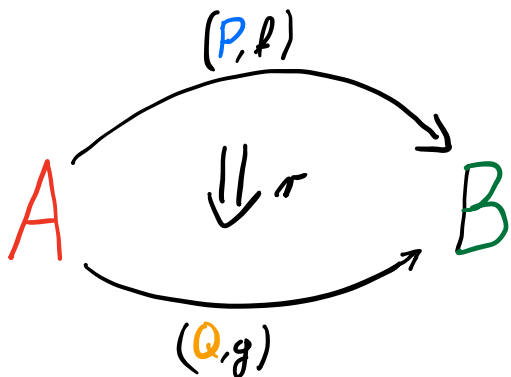

STANDARD  
STRING DIAGRAM

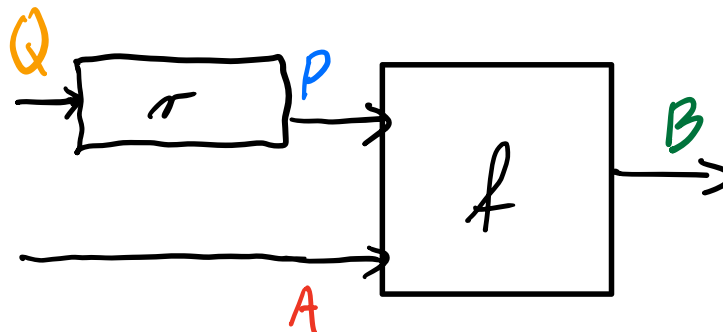
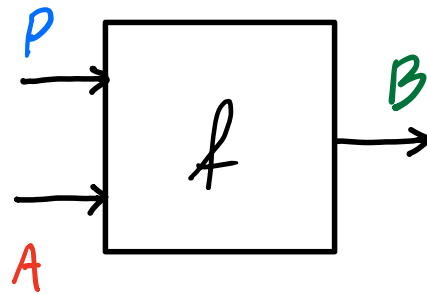

'2D'  
STRING DIAGRAM

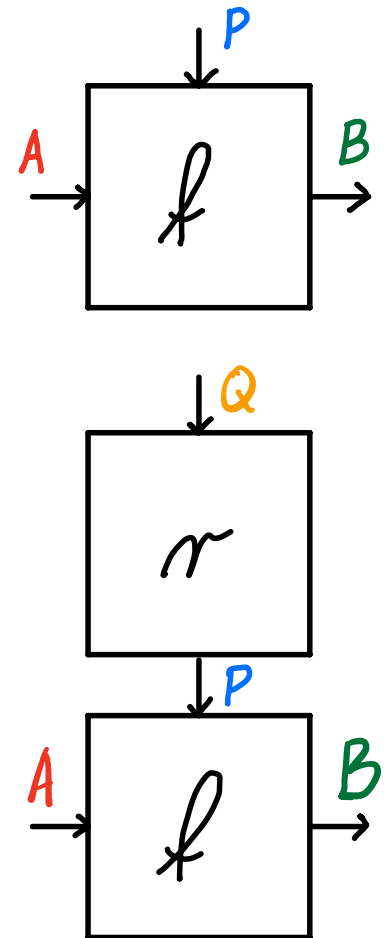

# EXAMPLE

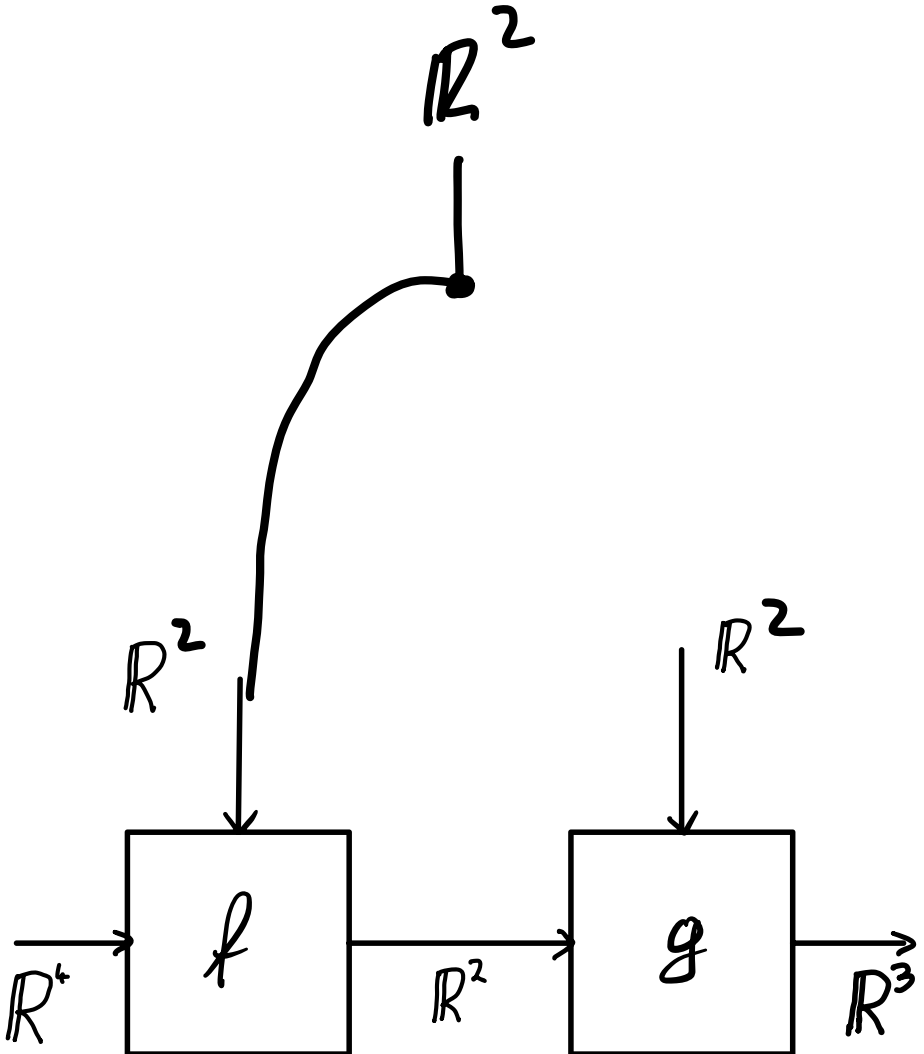
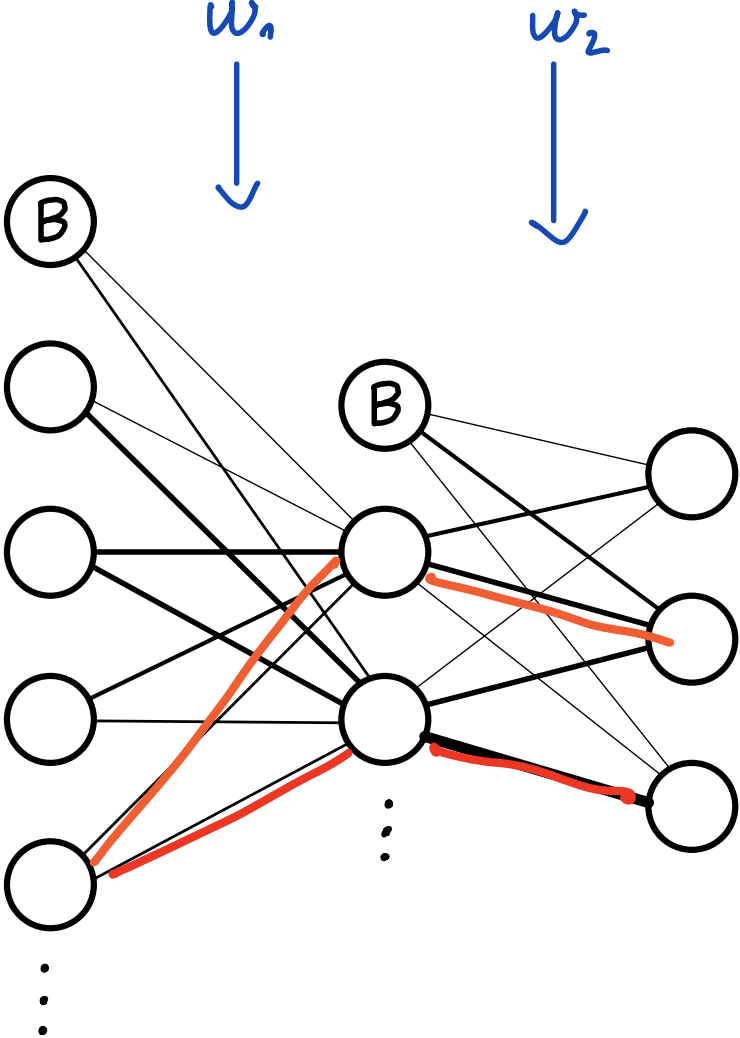

# CATEGORY OF OPTICS

- 2 PORTS ON THE DOMAIN  $\begin{pmatrix} X \\ X' \end{pmatrix} \xrightarrow{(M, f, b)} \begin{pmatrix} Y \\ Y' \end{pmatrix}$  2 PORTS ON THE CODOMAIN

DEF. AN OPTIC  $\begin{pmatrix} X \\ X' \end{pmatrix} \xrightarrow{(M, f, b)} \begin{pmatrix} Y \\ Y' \end{pmatrix}$  IS A CHOICE OF:

- TYPE OF THE INTERMEDIATE STATE  $M$  (THE RESIDUAL)
- FORWARD MAP  $f: X \longrightarrow Y \times M$
- BACKWARD MAP  $b: Y' \times M \longrightarrow X'$



# OPTICS CAN BE COMPOSED

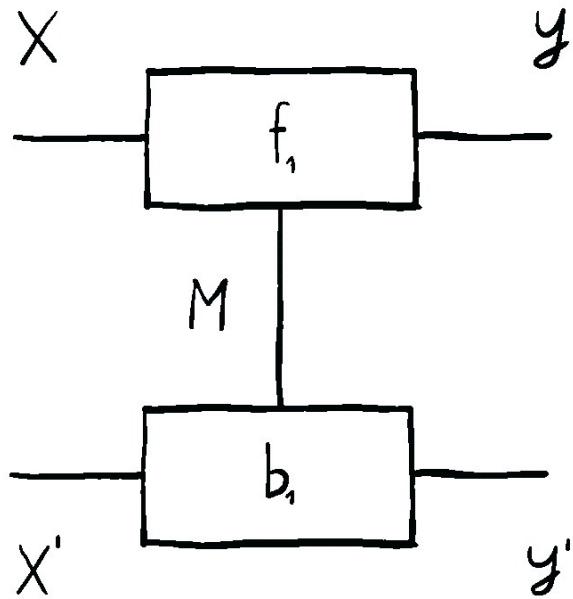

# PARAMETRIC LENS

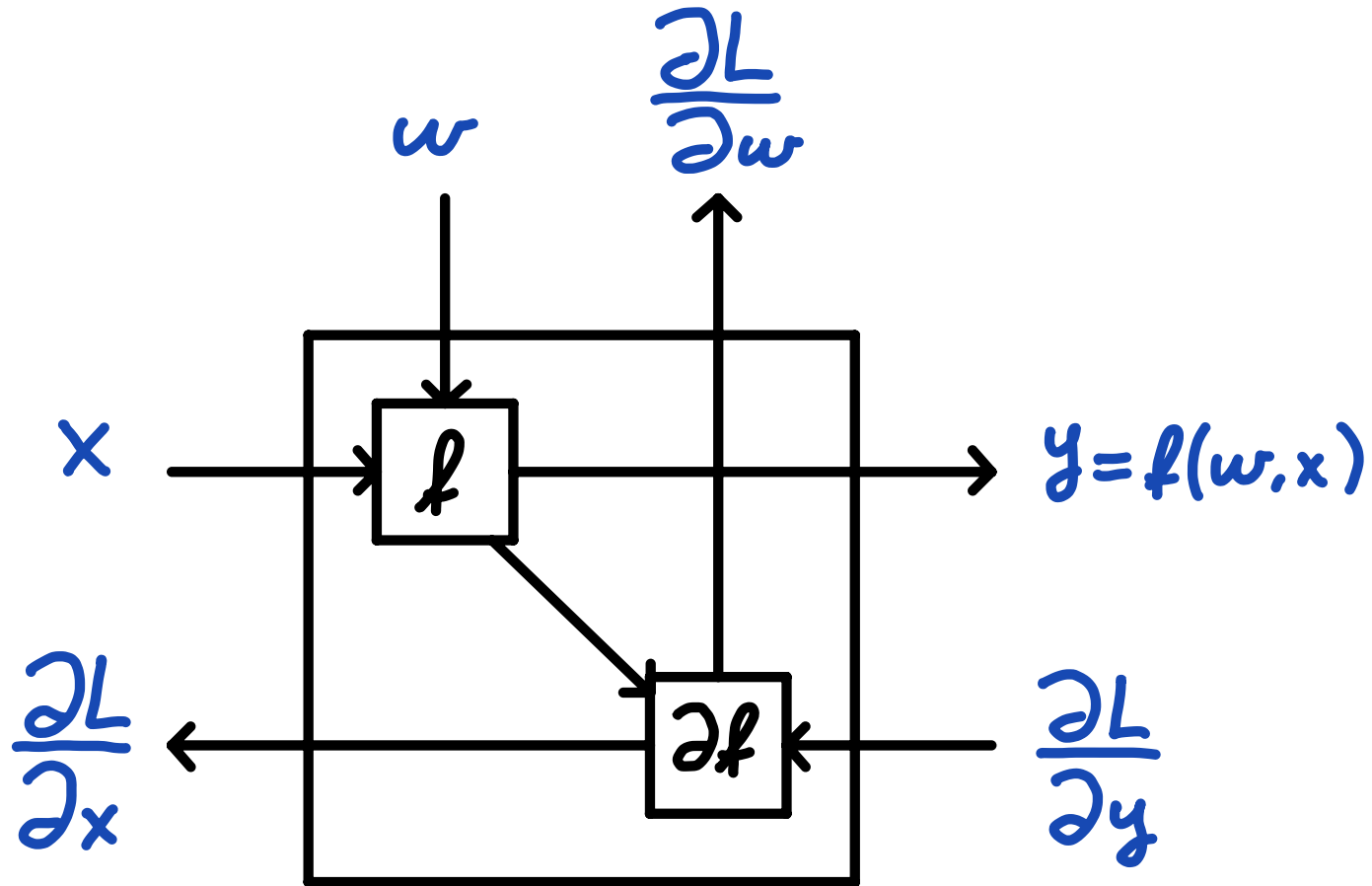

$$\text{Para}(e) \xrightarrow{\text{Para}(R)} \text{Para}(\text{Lens}(e))$$

• FRAMEWORK OF PARAMETRIC LENSES IS  
INCREDIBLY FLEXIBLE

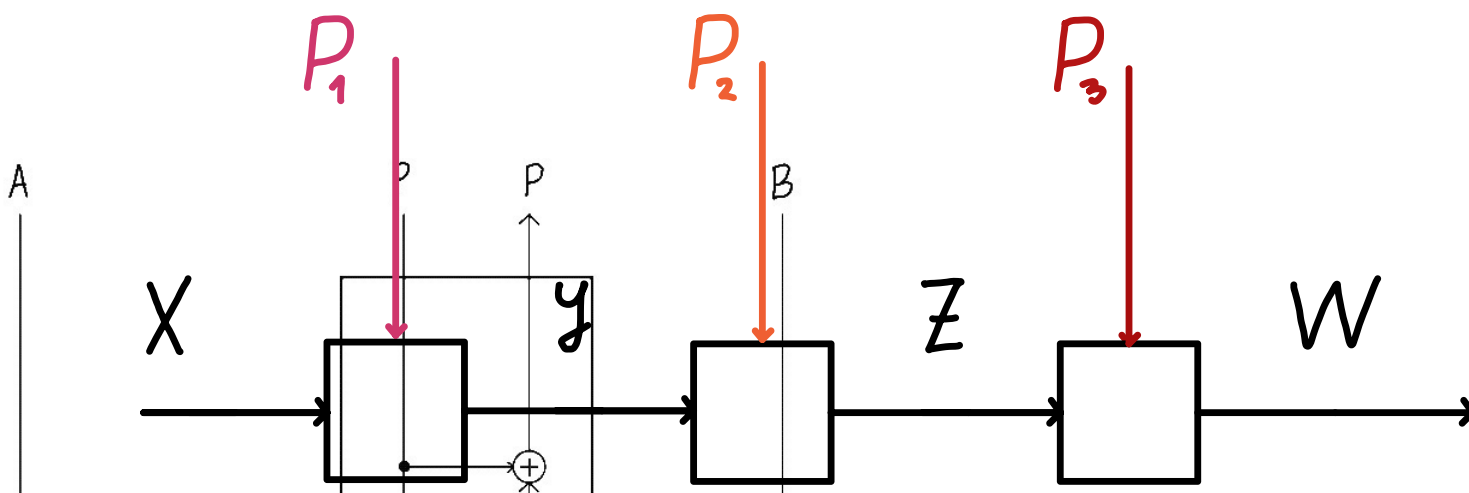

• I DOESN'T MAKE ANY ASSUMPTIONS ABOUT THE  
ARCHITECTURE, THUS MODELLING...

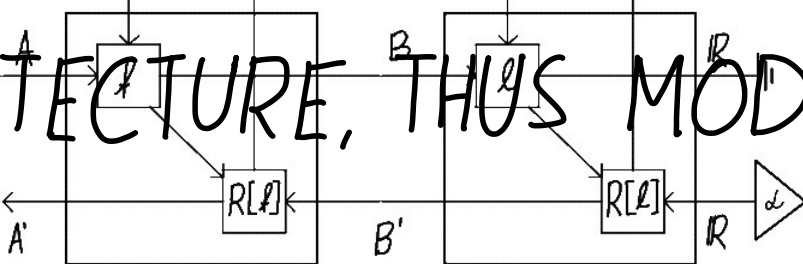

# RECURRENT NEURAL NETWORKS

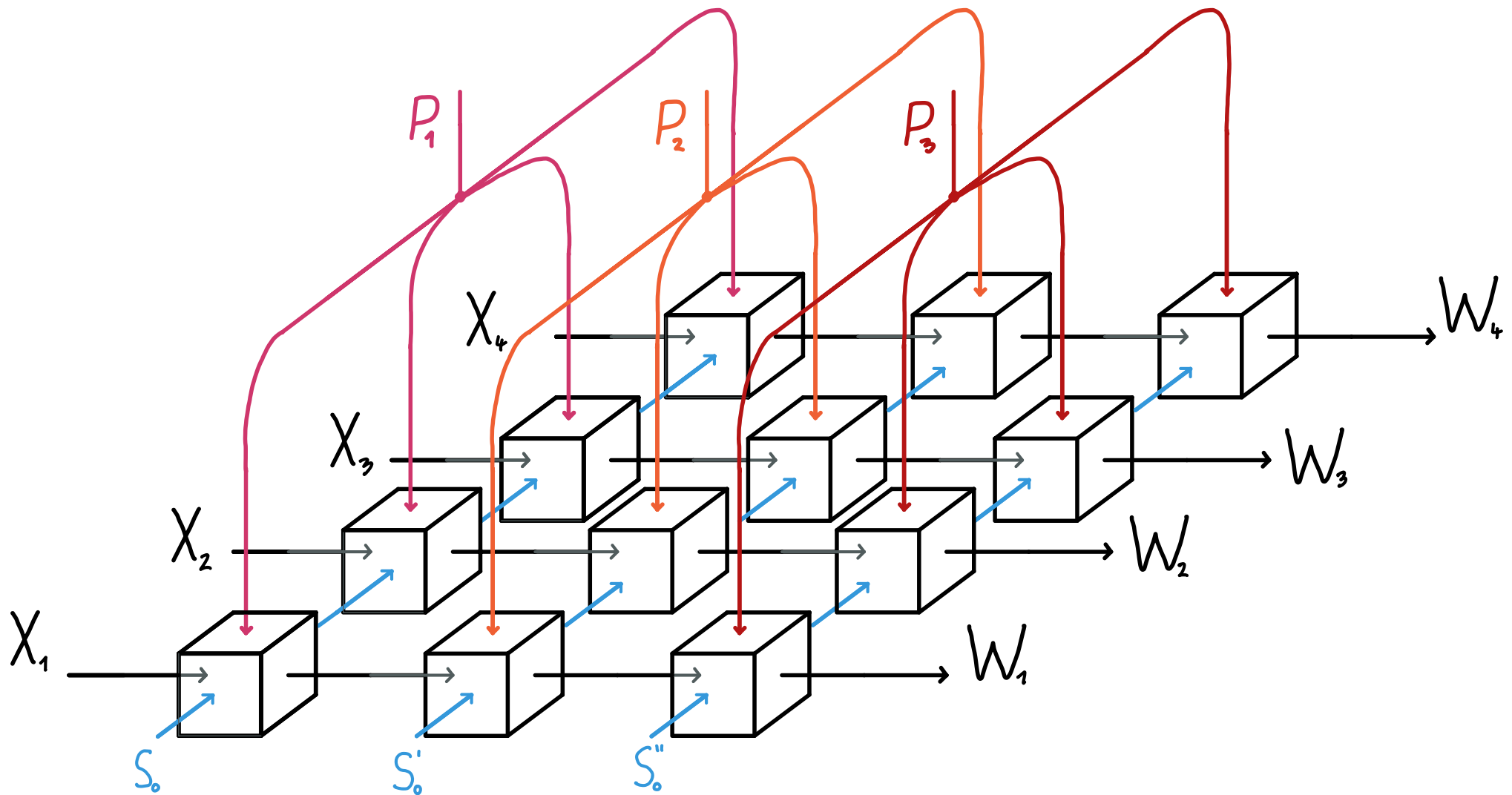

# GENERATIVE ADVERSARIAL NETWORKS

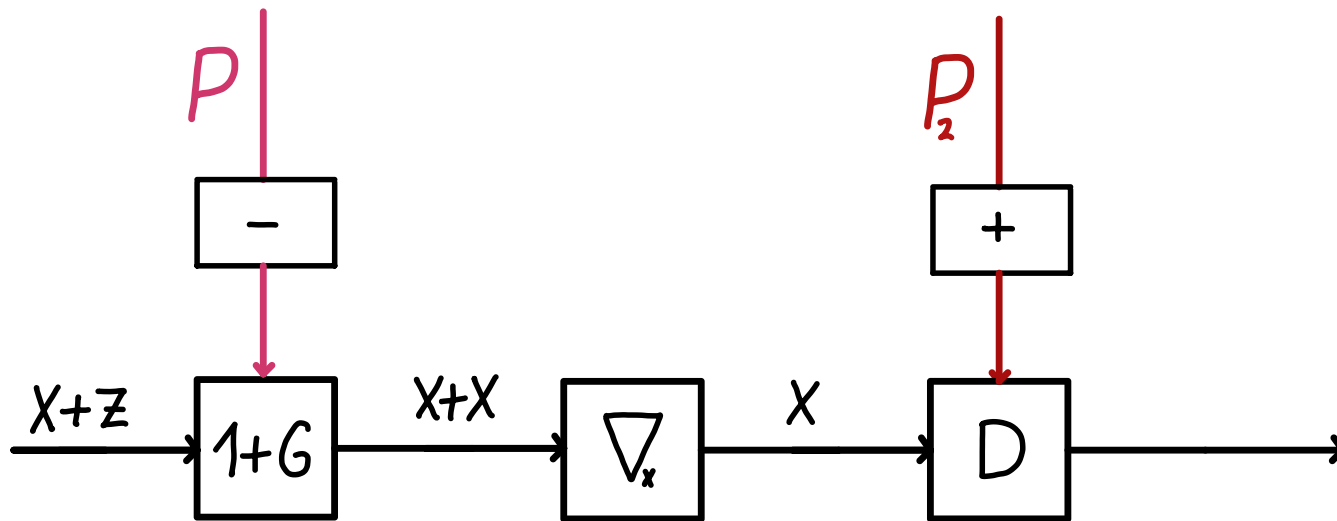

- CONVOLUTIONAL NEURAL NETWORKS
- RECURSIVE NEURAL NETWORKS
- GRAPH NEURAL NETWORKS

...

ALL OF THESE ARE JUST PARAMETRIC LENSES!

# FUTURE WORK

- GENERAL THEORY OF ARCHITECTURES?
- CONNECTIONS WITH GAME THEORY?  
BAYES RULE?  
RL?
- MUCH MORE!